



Site Readiness Guide

Residential properties
of 4 properties or less



Scottish & Southern
Electricity Networks

Powering our
community

About this guide

The purpose of this guide is to help you understand what you require to have in place to allow us to complete your network connection as smoothly and quickly as possible.

Find this guide online at:

www.ssen.co.uk/Connections/SmallProjects/

Useful contacts

 www.ssen.co.uk/connections

 0800 048 3516

 connections@sse.com

**In an emergency
situation call 105
immediately
for help**

**POWER CUT?
CALL 105**



If it's not safe, we don't do it

We believe that all work can and should be done safely. You should assume that all our overhead lines, underground cables, and electrical plant are live.

Please follow the Health and Safety Executive (HSE) Guidance Note GS6 if working near overhead lines, and the HSE Guidance Note HSG47 if working near underground cables.

Your SSEN Connections Project Delivery Manager

Name

Mobile

E-mail

Your to do list

- Register your postal addresses with Royal Mail or local authority**
Once registered, contact your regional hub so we can issue your MPAN

- Contact your electricity supplier to install your meter(s)**
Choose a supplier, register MPAN with them and arrange installation of meter

- Excavate cable trenches to the required width and depth and supply ducting**
For details please see pages 7-8

- Fit meter cabinet(s), meter backing board(s) and protective ducting**
For details please see page 8-13

- Ensure that the premises are securely locked and weather tight**

- Clear work area of any obstructions or hazards including any scaffolding near the agreed work areas**

Comments

Not ready in time ?

If you think you are not going to be ready on the agreed date, please contact us as soon as possible. Ideally you should give us a minimum of 5 days' notice. If we arrive on site and you are not ready we will be unable to commence works and may charge for the abortive visit.

Regional information

NORTH
(SHEPD)

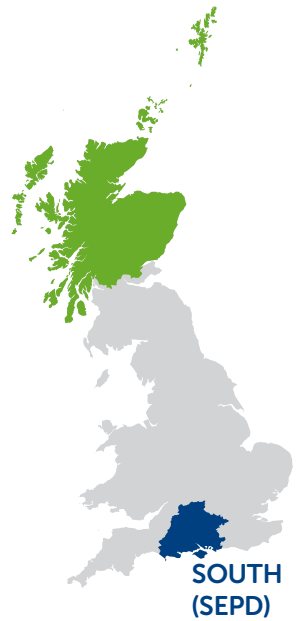

SOUTH

Please contact your dedicated Connections
Project Delivery Manager

Ridgeway

Thames Valley

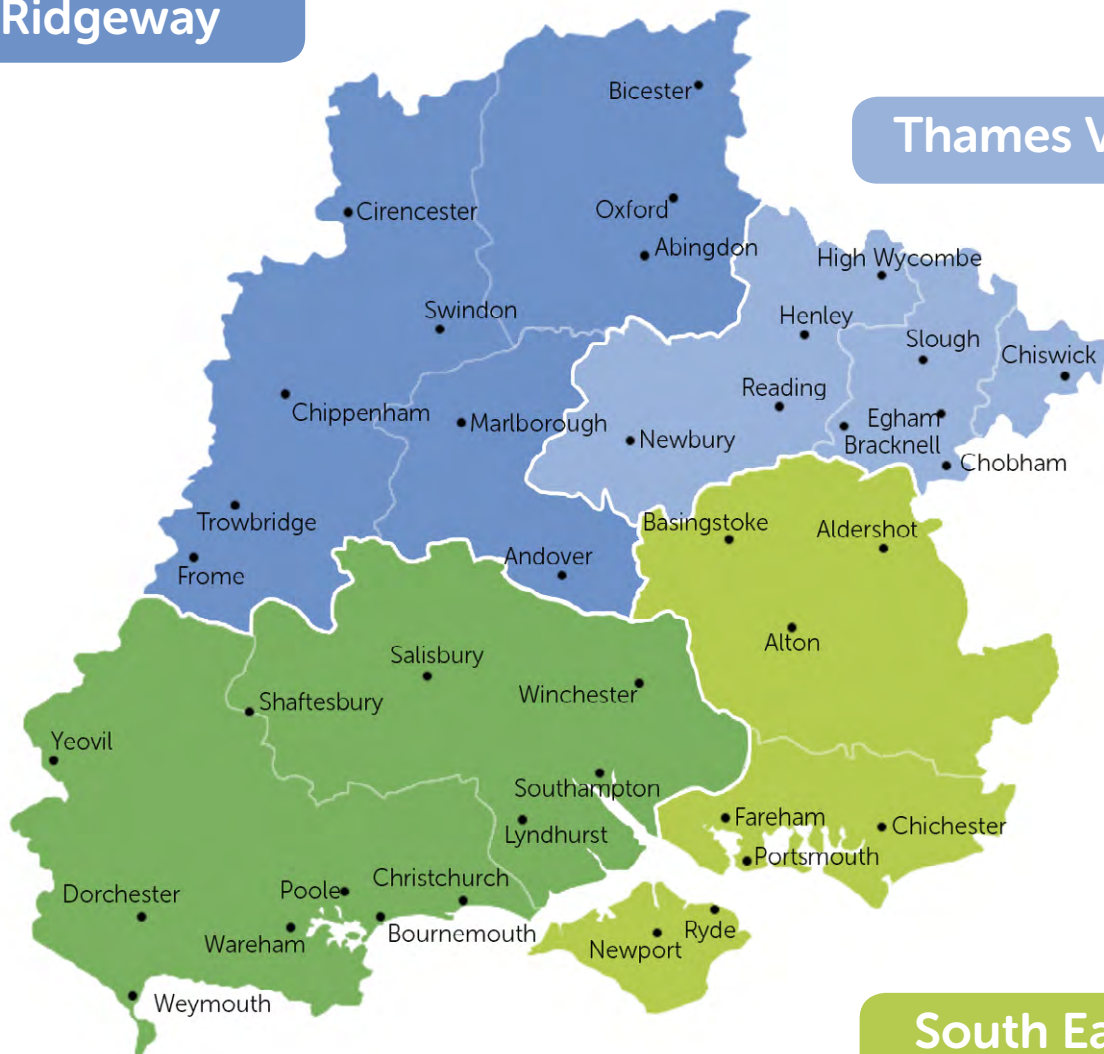

South East

Wessex

Regional information

NORTH



Please contact your dedicated Connections Project Delivery Manager

Highlands and Islands

North Caledonia

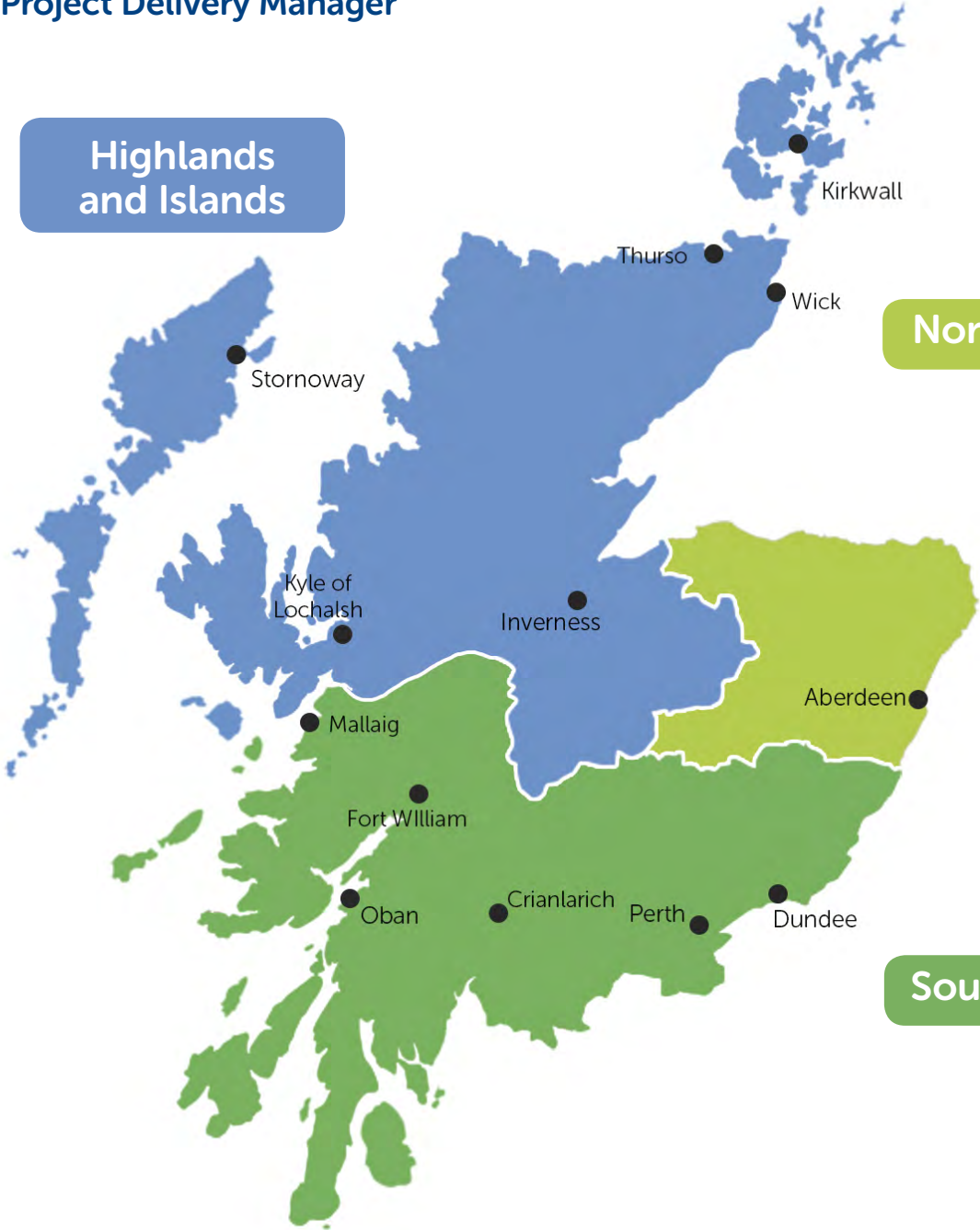

South Caledonia

Safe Working Practices

Working together to make your connection safe.

If you damage any of our underground cables you must report it to the Emergency Service Centre immediately by calling 105.

We want you to stay safe - especially when you are working near overhead lines and cables. Contact your Connections Project Delivery manager before you start work to make sure everything is secure and in accordance with health and safety regulations.

Overhead lines

Particular care must be taken when operating or handling mechanical plant, cranes, scaffolding or ladders in the vicinity of our overhead lines. You should always seek guidance before any work takes place on site from your appointed Connections Project Delivery Manager, who will ensure that all your works are carried out safely and in accordance with Health and Safety Guidance Instruction GS6 - Avoidance of Danger from Overhead Electric Power lines www.hse.gov.uk/pubns/gs6.htm

Underground cables

The drawing included with our connection offer may not be suitable for locating cables on site due to scaling issues. If you wish to obtain copies of our cable records for safe dig purposes, please contact www.linesearchbeforeudig.co.uk. You must hand-dig trial holes to establish actual positions of existing cables before using a mechanical excavator. Please follow the Health and Safety Executive (HSE) Guidance Note GS6 if working near overhead lines, and the HSE Guidance Note HSG47 if working near underground cables.

New Roads and Street Works Act

All excavation works required in the public highway will be carried out by SSEN or our designated contractors. The New Roads and Street Works Act 1991 require us to notify Local Authorities and other utility companies before we begin work to install our equipment. This is to ensure works are carried out to nationally agreed standards.

Please note we will only raise notifications after you have accepted our quotation and we have agreed with you a scheduled date to deliver the works.

The following are the minimum period of notice we are required to give:

- 3 days for minor works (works with a planned duration of 3 days or less)
- 10 days for standard works (works with a planned duration of between 4 and 10 days)
- 3 months for major works (works requiring a temporary traffic order and with a planned duration of 11 days or more)

Cable trenches, routes and depths

If you damage any of our underground cables you must report it to the Emergency Service Centre immediately by calling 105

The drawing included with our connection offer shows where you are required to dig, install ducts, fill cable trenches and joint bays. This will be confirmed during a site visit with your Connections Project Delivery Manager. Cable trenches must be dug to the dimensions shown in the drawing and table below.

The following trench section shows the position of duct in the ground. It is important that the top of any apparatus is at these depths as a minimum, this includes the top of the duct. In addition to the cable or duct there is a requirement for 75mm finefill material on all sides. Cable mark tape must be installed 75mm above the top of the apparatus, this needs to be branded with the SSEN logo. This is available from our approved suppliers.

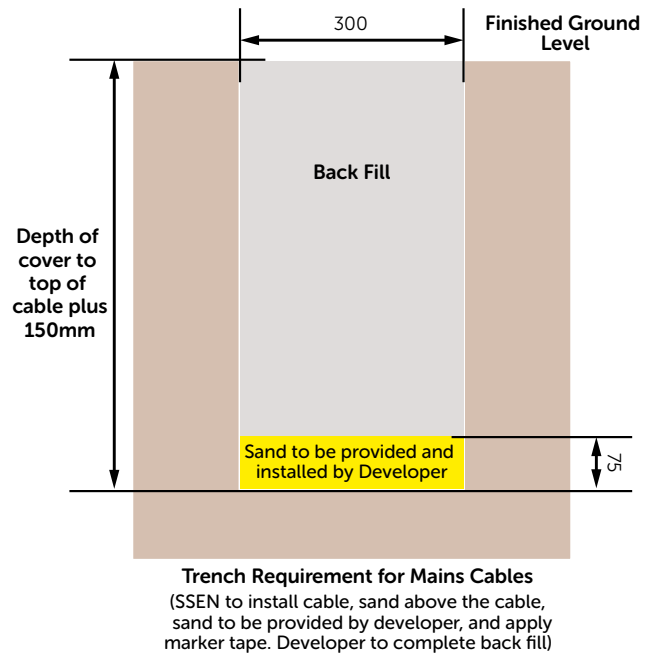
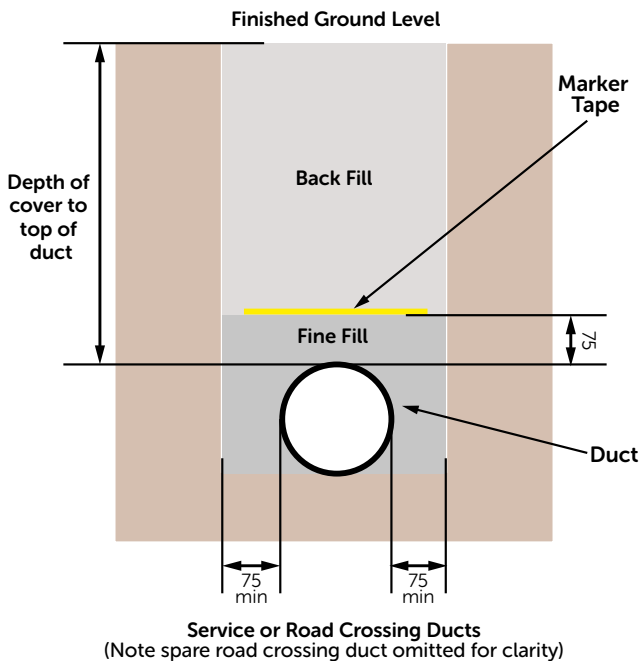

Cable trench depth

Ground type	Depth to top of cable / duct
Unmade, cultivated, or footpath	450mm
Driveway or road	600mm
Agricultural	1000mm

Where there are changes in surface type (e.g. footpath to carriageway) the excavations should always be the greater of the depths required. Ducted road crossings must be laid at a depth of not less than shown in the table and not more than 200mm deeper than shown in the table.

Where there are changes in surface type (e.g. footpath to carriageway) the excavations should always be the greater of the depths required. Ducted road crossings must be laid at a depth of not less than shown in the table and not more than 200mm deeper than shown in the table.

The crossings shall extend at least 150mm beyond the kerb line on either side of the road and the ends shall be blanked off to prevent ingress of spoil.

Please ensure that ducts provided for our use are spaced at least 1000mm clear of inspection pits and other duct lines to ensure adequate working clearance at the end of the ducts.

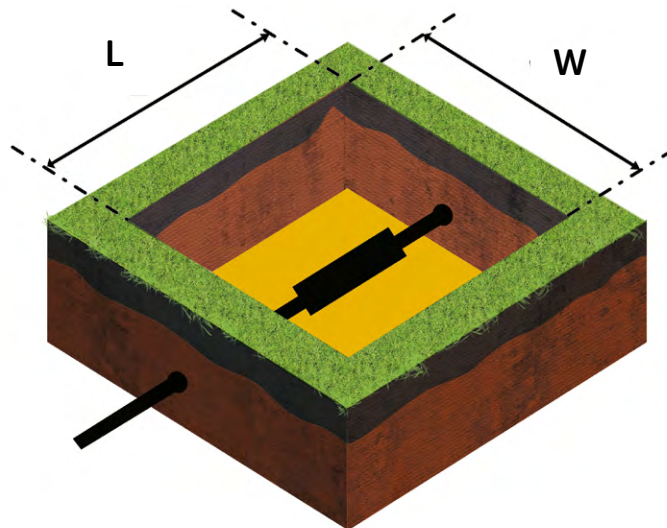

A guide for dimensions table below. This will be confirmed at your site visit

Straight joint	Breach joint	Pot end	Main Service Joint
1.5m x 1.2m	2.5m x 1.2m	0.9m x 0.9m	1.5m x 1.2m

Length and Width. Bottom of excavation to be 300mm below top of cable or duct.

Ducting with cables

The drawing provided with our connection offer shows where you are required to install ducting. You must supply and use **black electrical ducting** that has non ridged internal walls. Ducting shall comply with ENA TS 12-24. Minimum internal diameters of ducting are given in the table below. Please make sure you provide a draw wire or rope within the laid ducting so that we can pull the cable through.

Cable type	Minimum internal duct diameter
Single phase service cable	32mm
Three phase service cable	50mm
Main low voltage cable	150mm

An additional spare duct shall be installed with each duct bank crossing roads.

Ducting cables on site

For more detailed information on the ducting of cables please see our technical guidance document Installation of Electricity Service, Intake and Distributor Cables up to and Including 33kV available on our website.

www.ssen.co.uk/CompetitionInConnections/G81Documents/

Ducting of service cables

The drawing provided with our connection offer shows where you are required to install ducting.

Minimum internal diameters of ducting are given in the table below:

Cable type	Minimum Internal Diameter
Single phase service cable	32mm
Three phase service cable	50mm
Main low voltage cable	150mm

For single phase service cables, you are required to install a 32 mm internal diameter black electrical duct, from the joint position at the mains cable to the meter box.

For three phase service cables, a 50mm internal diameter black duct can be used although it is recommended a 100mm duct is used for lengths greater than 20m.

Ducts should be laid straight where possible with a minimum number of bends, and shall be marked with yellow unbranded or SSEN-branded tape.

Please refer to your design with regards to installing your ducts. Where bends are required please discuss with your Connections Project Delivery Manager.

It is important that you install a draw rope in the ducting to allow us to pull the cable through. You will be responsible for clearing the ducting if it gets blocked. Following cable installation, the ducts shall be sealed by the developer.

Trench backfilling and reinstatement

SSEN will cover all laid mains cables before leaving site. The sand for this activity must be provided by the customer and placed at regular intervals along the trench. You will be responsible for backfilling and completing the reinstatement of trenches and joint bays as indicated in your design.

The amount of sand to be provided is 4 tonne per 100 m of trench based on a trench of 300mm and a depth of sand of 75mm and assuming damp sand.

All reinstatement in footways or highways must comply with New Roads and Street Works Act 1991, 'Specification for the Reinstatement of Openings in Highways' and NJUG National Joint Utilities Group.

Please also refer to the Specification for Reinstatement of the Openings in Highways (SROH) (England) or Specification for Reinstatement of the Openings in Roads (SROR) (Scotland) for further guidance.

Internal main fuse (cut-out) positions

If you choose an internal termination position (where your meter operator will install the meter) follow our handy hints below.

Quick Guide

It must be:

- ✓ Located on the inside face of an external wall
- ✓ If applicable, gas meters must be located at least 300mm away from electrical equipment, and the space must be well ventilated

Must not be:

- ✗ In a cellar, toilet, bathroom, kitchen, bedroom, under stairs with headroom less than 2m
- ✗ Over a doorway
- ✗ On a partition stud dry-lined wall
- ✗ Or any other position not complying with the IET Wiring Regulations.

Internal main fuse (cut-out) positions

Meter board sizes and locations will depend on the type of supply being installed. Please see the illustration for guidance.

You must ensure that any electrical installation work beyond your supplier's meter is carried out by a qualified electrical contractor to the requirements of the current IET Wiring Regulations. The length of cable between your supplier's meter and the consumer unit must not exceed 3 metres.

Meters should be situated on the inside face of an external wall as close as possible to the incoming mains service and must not be installed in passageways that are designed as fire escapes, or where they could be enclosed, such as behind locked gates or in bin stores. Service terminations must not be installed in cellars, toilets, bathrooms, kitchens, bedrooms, under stairs with headroom of less than 2m, over doorways, on partition, stud dry-lined walls or any other position not complying with BS 7671.

Gas meters, where installed, must be at least 300 mm away from the electrical equipment with gas pipes at least 50 mm. The space must be well ventilated.

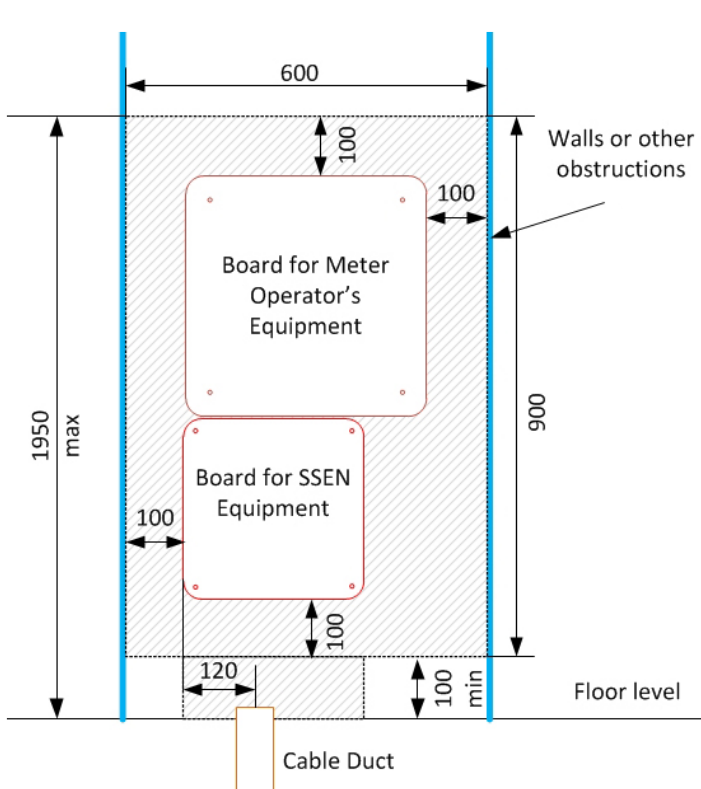

Wall space required for a single phase supply

Meterboard size for SSEN Equipment 300 x 300

Meterboard size for Meter Operator Equipment 400 x 400

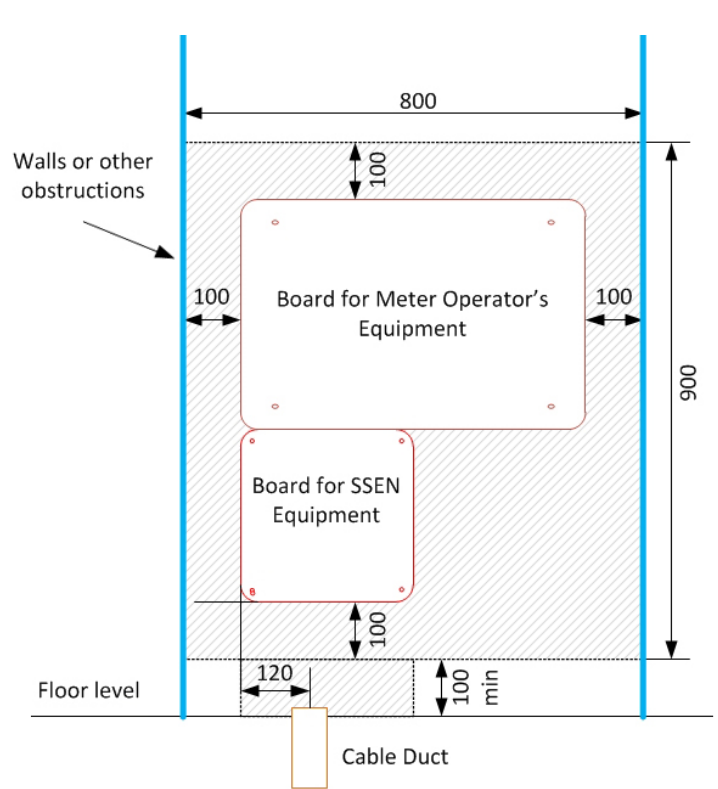

Wall space required for a three phase supply

Meterboard size for SSEN equipment 300 x 300

Meterboard size for Meter Operator equipment 600 x 400

Shaded area to be kept clear of obstructions

External main fuse (cut-out positions)

If you prefer an external meter position, please follow our handy hints below.

Quick Guide

It must be:

- ✓ You must supply the meter cabinet. They can be purchased from any builders merchants, and come complete with a hockey stick duct for the service cable.
- ✓ Meter cabinets come in 2 types - single or 3 phase please ensure you have the correct one to match your supply type
- ✓ The service cable duct must be securely coupled to the hockey stick. A surface mounted cabinet must be used for timber framed buildings.
- ✓ Meter cabinets located next to each other should have labels fitted inside to identify which premises they feed.

Must not be:

- ✗ Installed where it could be enclosed, such as behind locked gates or in bin stores.
- ✗ Installed in passageways that are designated fire escapes.

External main fuse (cut-out positions)

Flush Mounted with Hockey Stick in Cavity

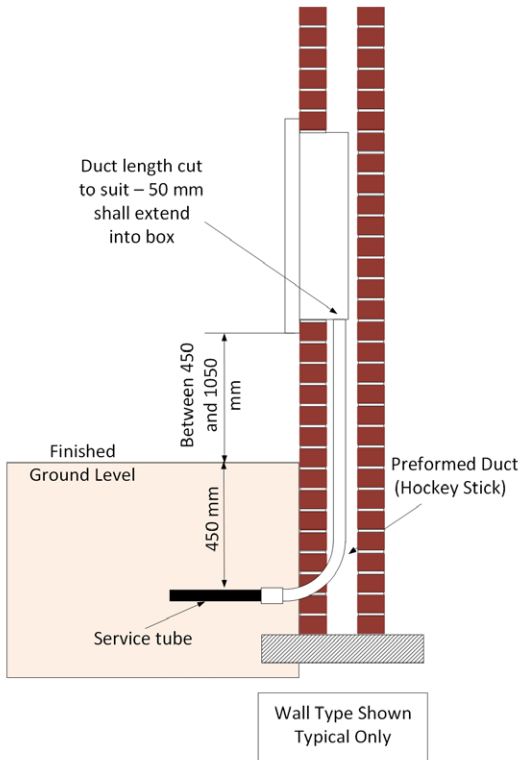

Surface Mounted with External Hockey Stick

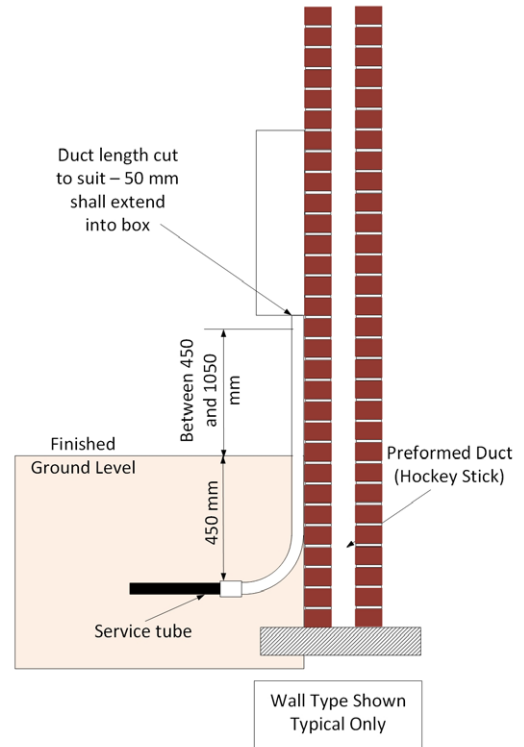

Flush Mounted with External Hockey Stick - Timber Framed

(or similar without full cavity)

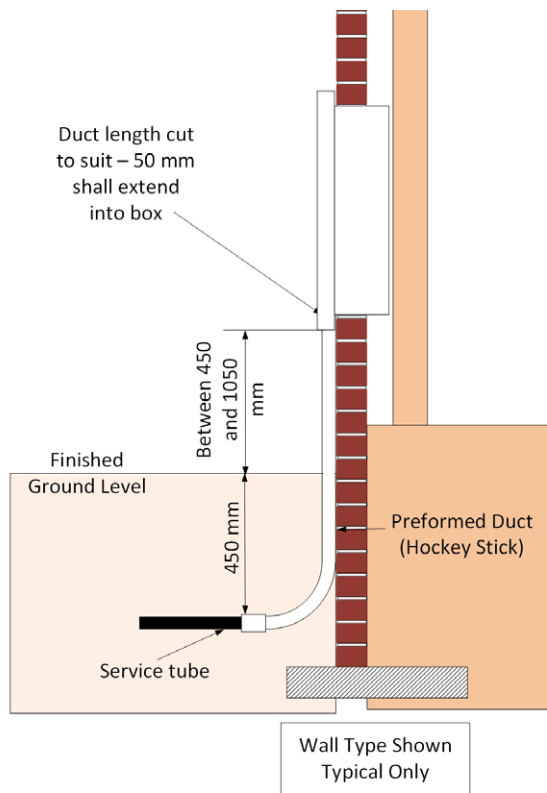

Flush Mounted with External Hockey Stick and Cable Cover - Timber Framed

(or similar without full cavity)

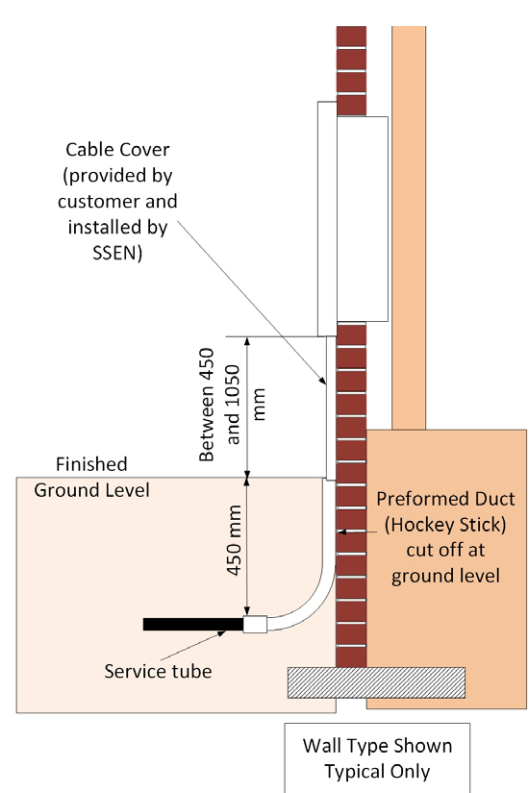

Meterboxes

The following table below gives details of suggested suppliers for meterboxes. Other suppliers, including some builder's merchants, can also supply these products. The information has been taken from the suppliers published information.

Recessed Type	Supplier		Suitable for Timber Framed Buildings
	Tricel	Mitras	
Large Recessed	✓	✓	✓
Medium Recessed	✓	✓	✓
Cavity Cable Entry via a hockey stick or Polyduct	✓	✓	✗
Cable entry on the face of the wall via hockey stick (medium box only)	✗	✓	✓
SSEN cable on face of Wall covered by a cable guard	✓	✓	✓
Surface Mounted Type			
Large Surface	✓	✓	✓
Medium Surface	✓	✓	✓
Cable entry on the face of the wall via hockey stick (medium box only)	✗	✓	✓
SSEN cable on face of Wall covered by a cable guard	✓	✓	✓

Notes;

- Medium boxes are not suitable for 3-phase supply terminations.
- Meterboxes shall comply with BS 8567.
- Meterboxes for indoor use shall be fire retardant. (BS 476, Part. 7, 1997, Class 2).
- Recessed boxes, where the cable is on the face of the wall, shall have manufacturer knock-outs incorporated. Boxes which have been adapted will not be accepted.
- The 38 mm Hockey stick is for single phase only, 38/50 mm Polyduct and cable guards shall be provided by the customer. These items shall be installed prior to SSEN installing the service cable. Cable guards, which must be available on site, preferable left in the meterbox, will be fitted by SSEN after installing the service cable.

Where an alternative supplier is used the meterboxes shall have the following minimum dimensions;

	Height mm	Width mm	Depth mm
Medium meter box external minimum dimensions	560	400	210
Large meter box external minimum dimensions	750	520	190

Where an equivalent to Polyduct is provided it must be black and comply with the requirements of ENATS 12-24 and be to class 3.

Consumer unit and internal wiring

The length of cable between your supplier's meter and the consumer unit if greater than 3m should incorporate an isolator switch . You must ensure that any electrical installation work beyond your supplier's meter is carried out by a qualified electrical contractor to the requirements of the current IET Wiring Regulations.

Your meter installation appointment

You are now ready for your meter installation by your elected electricity supplier.

It is the customer's responsibility to arrange for the meter to be installed.

On the day of your installation your electrician will need to attend your agreed appointment with your electricity supplier. This is to connect your meter tails between the energy supplier's meter and consumer unit or isolator.

Consumer unit

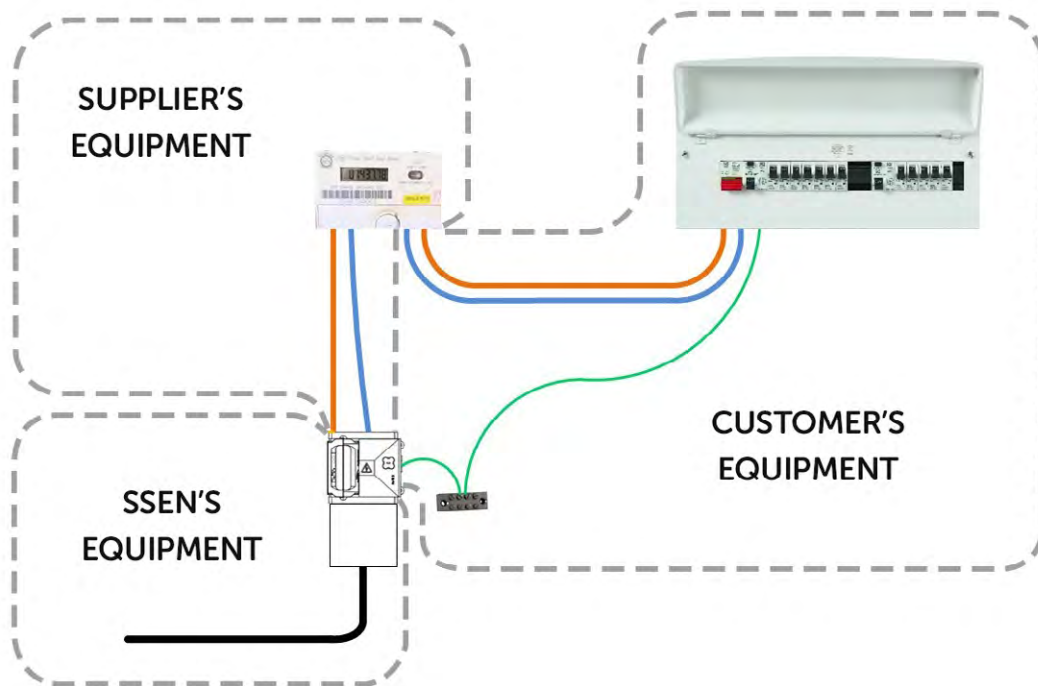

Service terminations at upper levels

Where connections are to be made to premises on the first floor or above, you must provide and install suitable external or internal containment for the service cable to the termination position. Internal containment must be routed through common areas of the building so that the cable is always accessible, without the need to enter a third party's property, in case of the need for emergency repair.

We will not run our cable in walls, lofts, lift shafts, or other cavities not specifically designed to contain cables.

Glossary

Term	Definition
Inspection pits	Open areas of trench where the depth of the contained duct can be measured and the use of sand and marker tape can be witnessed
Joint bays	The hole in which the joint to a cable will be made
Hockey stick	A piece of plastic pipe in the shape of a hockey stick which is used to protect the cable between the ground and the meter cabinet
IET Wiring Regulations BS7671	Wiring regulations for domestic and commercial electrical installations - https://electrical.theiet.org/resources/digital/
Single Phase service	Typically a small domestic or commercial supply, less than or equal to 69kVA
Three Phase service	Typically a large domestic or commercial supply, greater than 69kVA
ENATS 12-14	Technical Specification for Plastic Ducts for Buried Electrical Cables, an official ENA document
MPAN	Meter Point Administration Number, your unique 21-digit reference number for your supply point

How to reach us



More information

www.ssen.co.uk/connections



Call us

0800 048 3516



Email us

connections@sse.com

In an emergency situation
call **105** immediately for help

**POWER CUT?
CALL 105**



Scottish & Southern
Electricity Networks

Powering our
community